

CVMA-250BA/70-AAB-P

Old Type Designation: CV5A-250ES

Specifications	
Capacity C_{max} (nominal)	250 pF
Capacity C_{min} (nominal)	18 pF
Voltage (Peak Test U_{pt} / Peak Working U_{pw})	70 kV / 42 kV
Capacity Tolerance (linear Range)	10%
Max. Current I_{max} at 13.56 MHz with Air Cooling	219 Arms 200 l/min
Capacitance per turn	5 pF/turn
Torque	≤ 1.5 Nm
Net Weight	8.7 kg

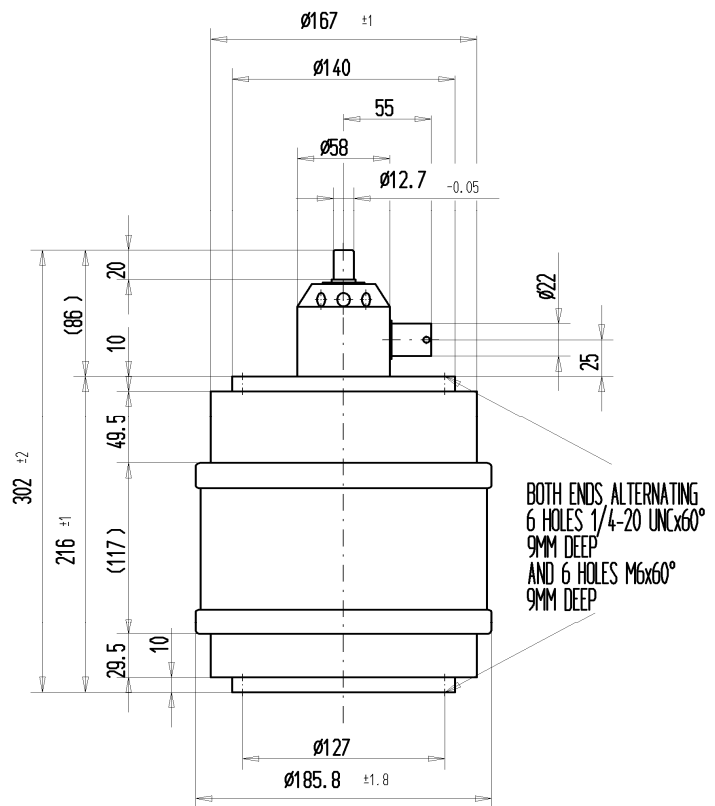
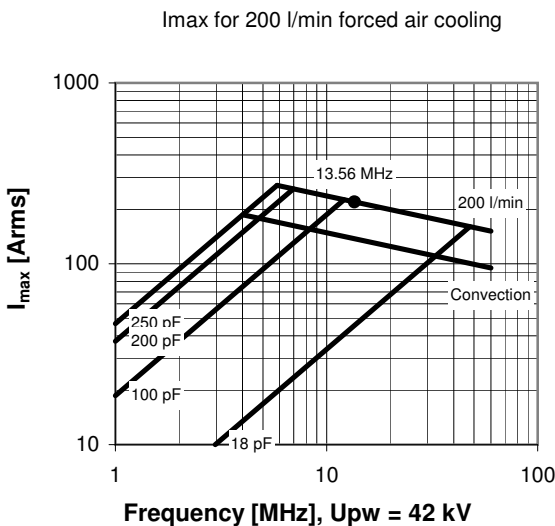
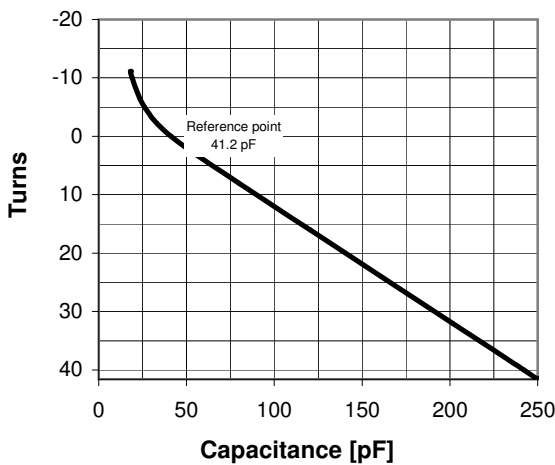

Turns	Nominal Capacitance [pF]	Tolerance
-11.1	18.0	10%
-10.0	19.0	10%
-5.0	26.1	10%
0.0	41.2	0%
8.0	79.7	10%
16.0	120.3	10%
24.0	160.9	10%
32.0	201.5	10%
40.0	242.1	10%
41.6	250.0	10%

Mechanical stop at < 18 pF at ~ -18.2 turns
Mechanical stop at > 250 pF at ~ 42.9 turns

Self inductance and resonance frequency

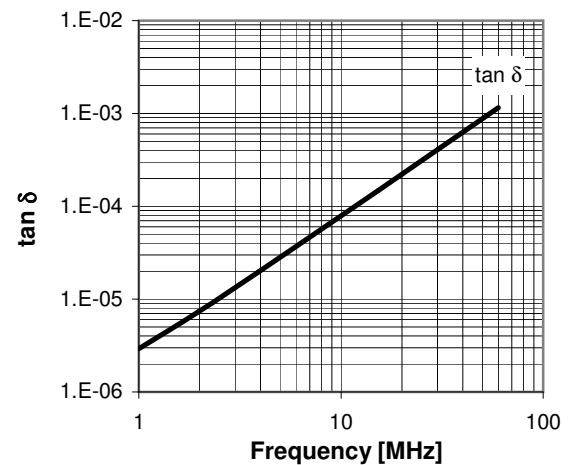
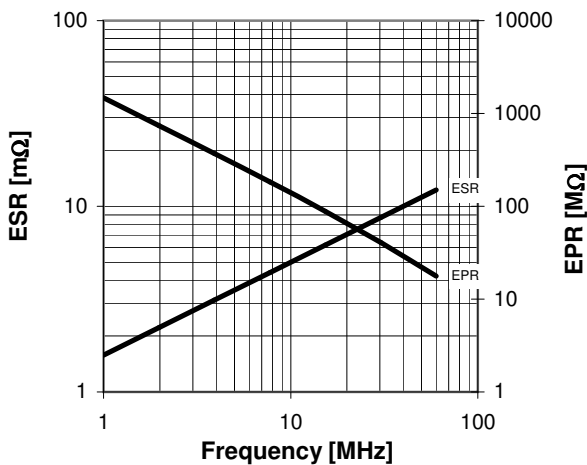
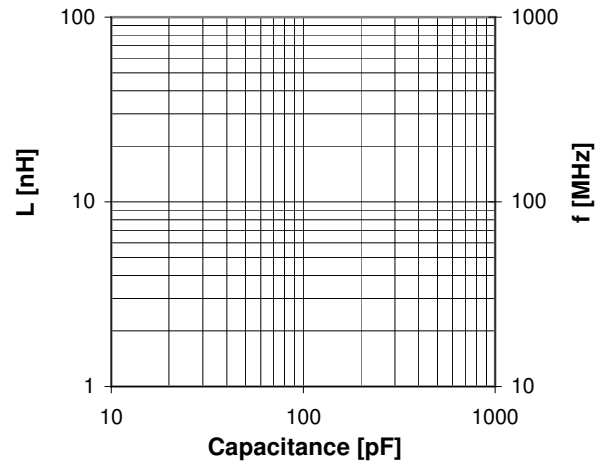

Special Features:

Lubrication System

Type Ordering Information:

Type	Upt
CVMA-250BA/70-AAB-P	70 kV
CVMA-250BA/65-AAB-P	65 kV
CVMA-250BA/60-AAB-P	60 kV