

# Motorized Capacitor

## Electrical Installation of ID-400



### Document Information

---

Authors ..... O. Lehmann / A. Renggli / T. Fenske  
..... W. Bigler / M. Armbruster  
Document ..... SB-63\_Electrical Installation ID-400.docx  
Created on ..... 30-Mar-2007  
Revision ..... 03  
Comment ..... Revised version, 14-Feb-2018

## Document history

---

Doc. Rev.	Date	Author(s)	Change(s)	Status
1.0	2007-03-30	O. Lehmann	Initial document	released
1.1	2010-06-25	A. Renggli	Various additions	internal
02	2014-01-24	W. Bigler / T. Fenske	Reviewed with minor modifications / configuration section added	released
03	2018-02-14	M. Armbruster / T. Fenske	Added UNIVERSAL variant, minor corrections	released

## Table of Contents

<b>1</b>	<b>Overview of Driver Unit ID–400</b>	<b>4</b>
<b>2</b>	<b>Stepper motor for all variants</b>	<b>4</b>
<b>3</b>	<b>Stepping driver controller Interface for EXPERT</b>	<b>5</b>
3.1	Communication Interfaces	5
<b>4</b>	<b>Controller Board Connections for EXPERT variant</b>	<b>6</b>
4.1	Connectors of EXPERT variant	6
4.1.1	X1 Connector - Power supply	6
4.1.2	X2 Connector - Additional I/O	7
4.1.3	X3 Connector - Serial interface	7
4.1.4	X4 and X5 connector	7
4.1.5	X6 Connector – Motor connector	7
4.2	Jumpers J1, J2, J3 and J4	8
4.3	Operating ratings of EXPERT variant	8
4.4	Technical Specification of the PCB	9
4.5	Connecting the Module	9
<b>5</b>	<b>Controller Board Connections for UNIVERSAL variant</b>	<b>10</b>
5.1	Connectors of UNIVERSAL variant	10
5.1.1	Power supply & interface connector	10
5.1.2	Motor connector	11
5.2	Operating ratings of UNIVERSAL variant	11
5.3	Mechanical installation	12
<b>6</b>	<b>Revision history</b>	<b>13</b>

## 1 Overview of Driver Unit ID-400

Picture 1 Component parts for driver unit ID-400.

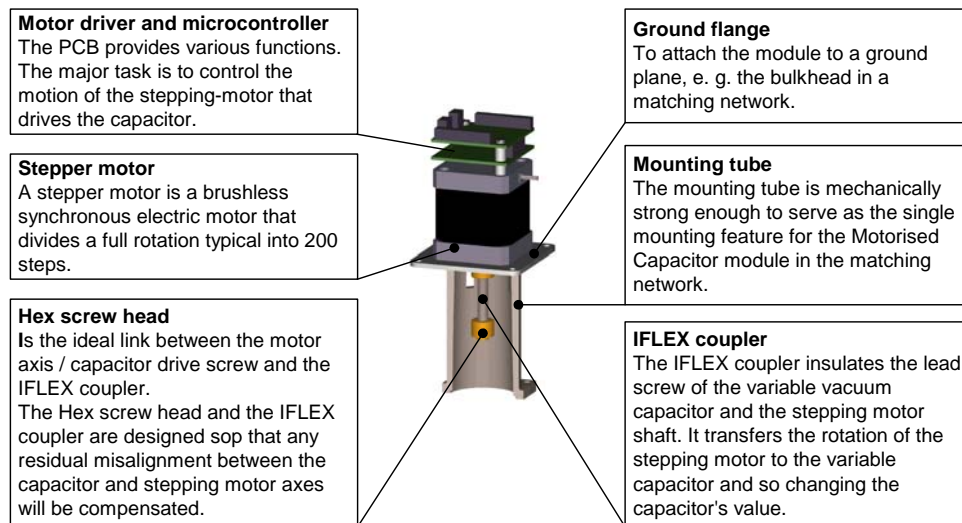

Fig. 1: Components of the driver unit ID-400

## 2 Stepper motor for all variants

The BASIC und UNIVERSAL variant of the ID-400 is equipped with an Oriental Motor PK244PA which can be operated in unipolar or bipolar mode. This well proven standard stepper motor is able to drive the ID-400 up to 600 rpm in unipolar mode.

For detailed technical information please refer to the supplier's website <http://www.orientalmotor.com/>

The ENTRY and EXPERT variant of the ID-400 is equipped with a Lin-Engineering Motor, which can be operated bipolar mode only. Due to the higher torque it is able to drive the ID-400 up to 1200 rpm.

For detailed technical information please refer to the supplier's website <http://www.linengineering.com/>

## 3 Stepping driver controller Interface for EXPERT

### 3.1 Communication Interfaces

The interface between the controller unit (e.g. PC) and the driver board is the communication interface. Specifications of the COMET proprietary communication protocols are available for the RS-232 interface.

## 4 Controller Board Connections for EXPERT variant

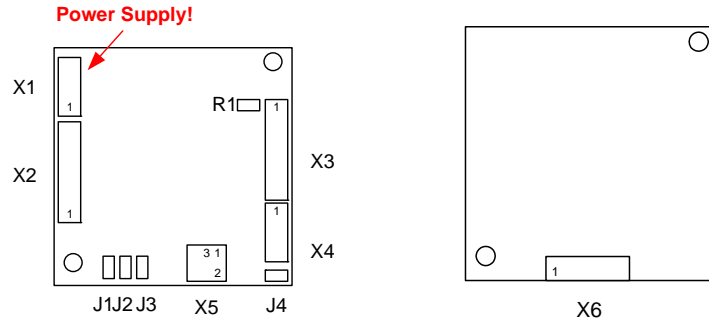

Fig. 2: Layout of the PCB

The left hand layout in Fig. 2 shows the top board, the right hand layout shows the bottom board.

### 4.1 Connectors of EXPERT variant

#### 4.1.1 X1 Connector - Power supply

Power is provided to the PCB through this connector. To ensure a proper flow of current, all pins of the connector must be used. The product will be shipped with a female connector that is compatible with the X1 connector on the board including the required wires.

Pin	Function	Color
1	+ 7 ... 28 V DC	red
2	+ 7 ... 28 V DC	red
3	GND	black
4	GND	black

Table 1: Pin layout of connector for X1 for the ID-400 (V.1.2)

Power supply voltage can be +7...+28 V DC. A higher voltage gives higher motor dynamics. Please note that there is no protection against reverse polarity or over voltage. The power supply should be designed such that it supplies the nominal motor voltage at the desired maximum motor power. The supply voltage must never exceed or fall below the upper / lower voltage limits.

To ensure reliable operation of the unit, the power supply has to have a sufficient output capacitor and the supply cables should be of low resistance so that the chopper operation does not lead to an increase in power supply ripple. Power supply ripple due to the chopper operation should be kept to a maximum of 200-300mV. This also is important in order to make the user's application compatible to any applicable EMC guidelines.

Therefore it's recommended that:

- power supply cables are kept as short as possible
- reasonable diameter of power supply cables are used (AWG22 or larger)
- if the distance to the power supply is more than 2 - 6m) a robust 470µF or larger additional filtering capacitor needs to be located near to the motor driver unit.

## 4.1.2 X2 Connector - Additional I/O

When pin 7 is connected to +5V DC the ID-400 will start with a reference drive. This feature is available from driver software version V.1.1.0. All other pins have no functionality.

Pin	Function
1	Left limit switch
2	Right limit switch
3	GND
4	General purpose output
5	VDD (same as connector X1, pin1)
6	GND
7	General purpose input
8	+ 5 V DC output (max. 20 mA)

Table 2: Pin layout of connector X2

## 4.1.3 X3 Connector - Serial interface

This connector provides access to and from the PCB via serial interfaces, i.e. RS-232. Jumper J1 is used to select the proper serial interface port.

Pin	EXPERT-1
	RS-232
1	TxD
2	RxD
3 to 8	+0V (GND)

Table 3: Pin layout of connector X3

## 4.1.4 X4 and X5 connector

Connectors X4 and X5 are not used and have to be unplugged.

## 4.1.5 X6 Connector – Motor connector

Pin	Function	Color of Lin stepping motor: 4118L-26P-02
1	OA1 (motor)	red
2	OA2 (motor)	blue
3	OB1 (motor)	green
4	OB2 (motor)	black

Table 4: Pin layout of connector X6 for the stepping motor

**!! The motor must never be unplugged during operation !!**

## 4.2 Jumpers J1, J2, J3 and J4

These jumpers have the following functionality:

J1: Interface selection. This jumper selects which interface is to be used when the module starts up. For RS-232 this jumper is open.

J2: Close jumper to terminate the step-signal with a 120  $\Omega$  resistor

J3: Close this jumper to terminate the CAN/RS-485 bus with a 120  $\Omega$  resistor.

J4: Close jumper to terminate the direction-signal with a 120  $\Omega$  resistor

	RS-232
Jumper – J1	Open
Jumper – J2	Close
Jumper – J3	Open
Jumper – J4	Close

Table 5: Jumper position

## 4.3 Operating ratings of EXPERT variant

Sympl	Parameter	Min	Typ	Max	Unit
V <sub>S</sub>	Power supply voltage for operation	7	12...24	28	V
I <sub>COIL</sub>	Motor coil current for sine wave peak (chopper regulated, adjustable via software)	0	0.4...4.0	4.0	A
I <sub>MC</sub>	Continuous motor current (RMS)	0	0.3...2.8	2.8	A
f <sub>CHOP</sub>	Motor chopper frequency		36.8		kHz
I <sub>S</sub>	Power supply current		<< I <sub>COIL</sub>	1.4 * I <sub>COIL</sub>	kHz
U <sub>+5V</sub>	+5V output (max. 20mA)	4.8	5.0	5.2	V
V <sub>GPO</sub>	Open collector output, max. 100mA, freewheeling diode included			V <sub>S</sub>	V
V <sub>ANA</sub>	GPI analog measurement range (range switchable)		0 ... 5 0 ... 10		V
V <sub>STOPLO</sub>	StopL, StopR low level input		0	0.9	V
V <sub>STOPHI</sub>	StopL, StopR high level input (integrated 10k pullup to +5V)	1.9	5		V
T <sub>ENV</sub>	Environment temperature at rated current (no forced cooling required)	-40		45	°C
T <sub>ENV</sub>	Environment temperature at 80% of rated current or 50% duty cycle (no forced cooling required)	-40		60	°C

Table 6: Operation ratings for the ID-400



## 4.4 Technical Specification of the PCB

- Size: 42mm x 42mm
- Height: 18mm
- Two mounting holes (M3), see also Figure 4.1
- Supply voltage: 7..28V DC
- Connector type:
  - Power Supply: PHR-5
  - Additional I/O connector, RS232/RS485/CAN connector: PHR-8
- Stepper motor type: two phase bipolar
- Maximum coil current: 4.0A
- Inputs:
  - One general purpose (digital (TTL) or analogue (0..+5V))
- Output:
  - One +5V output, max. 20mA

## 4.5 Connecting the Module

- Please always make sure that the boards are connected together correctly before connecting the power supply.
- Never connect or disconnect a motor when the module is powered, as this may damage the module. Also, the motor driver is not protected against short circuits to ground.

## 5 Controller Board Connections for UNIVERSAL variant

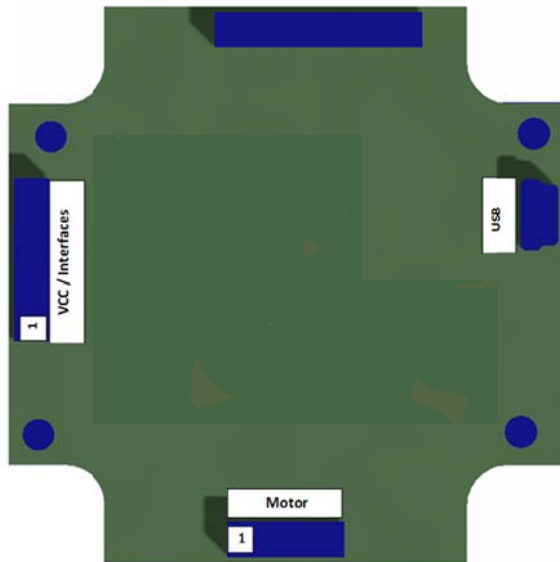

Fig. 3: Connectors on PCB of UNIVERSAL motorized capacitor

### 5.1 Connectors of UNIVERSAL variant

#### 5.1.1 Power supply & interface connector

There is no protection against over-voltage or reverse polarity. The power supply should be designed such that it supplies the nominal motor voltage at the desired maximum motor power. The supply voltage must never exceed the upper / lower voltage limits.

For further information regarding power ripples and EMC guidelines refer to chapter 4.1.

Either one of the interface (RS232 or RS485) can be used at a given time.

Pin	Function
1	GND
2	VCC: +24V DC nominal (10... 30V DC)
3	RS485 (A+)
4	RS485 (B-)
5	RS232 (TX)
6	RS232 (RX)

Table 7: pin layout of connector: VCC / Interfaces

### 5.1.2 Motor connector

Pin	Function
1	OA1 (stepper motor phase A)
2	OA2 (stepper motor phase A)
3	OB1 (stepper motor phase B)
4	OB2 (stepper motor phase B)

Table 8: pin layout of connector: motor

## 5.2 Operating ratings of UNIVERSAL variant

Sympl	Parameter	Min	Typ	Max	Unit
$V_S$	Power supply voltage for operation	10	24	30	V DC
$I_{COIL-PEAK}$	Motor coil current for sine wave peak (chopper regulated, adjustable via software)	0	0.4...4.0	4.0	A
$I_{COIL-RMS}$	Continuous motor current (RMS)	0	0.3...2.8	2.8	A
$I_S$	Power supply current		$\ll I_{COIL}$	$1.4 * I_{COIL}$	kHz
$V_{GPO}$	Open collector output, max. 100mA, freewheeling diode included			$V_S$	V
$V_{STOPHI}$	StopL, StopR high level input (integrated 10k pullup to +5V)	1.9	5		V
$T_{ENV}$	Environment temperature at rated current (no forced cooling required)	-35		50	°C
$T_{ENV}$	Environment temperature at 80% of rated current or 50% duty cycle (no forced cooling required)	-35		60	°C

Table 9: Operation ratings for the ID-400

### 5.3 Mechanical installation

The ground flange is provided with 4 off M4 threaded holes to locate and fix the module to the ground plane or bulkhead assembly. A torque not exceeding 1.5 Nm shall be used to tighten screws inserted into these threaded holes. This is best controlled carefully by use of a calibrated torque wrench, screw driver or similar device.

The PCB is mounted on a plastic PCB holder which is supplied separated from the stepper motor. The PCB holder can be mounted by clipping onto the stepper motor (see Figure 4 below, please respect the correct orientation). It can also be mounted separately, away from the stepper motor using the cut outs available on the side of the plastic PCB holder for location and fixing.

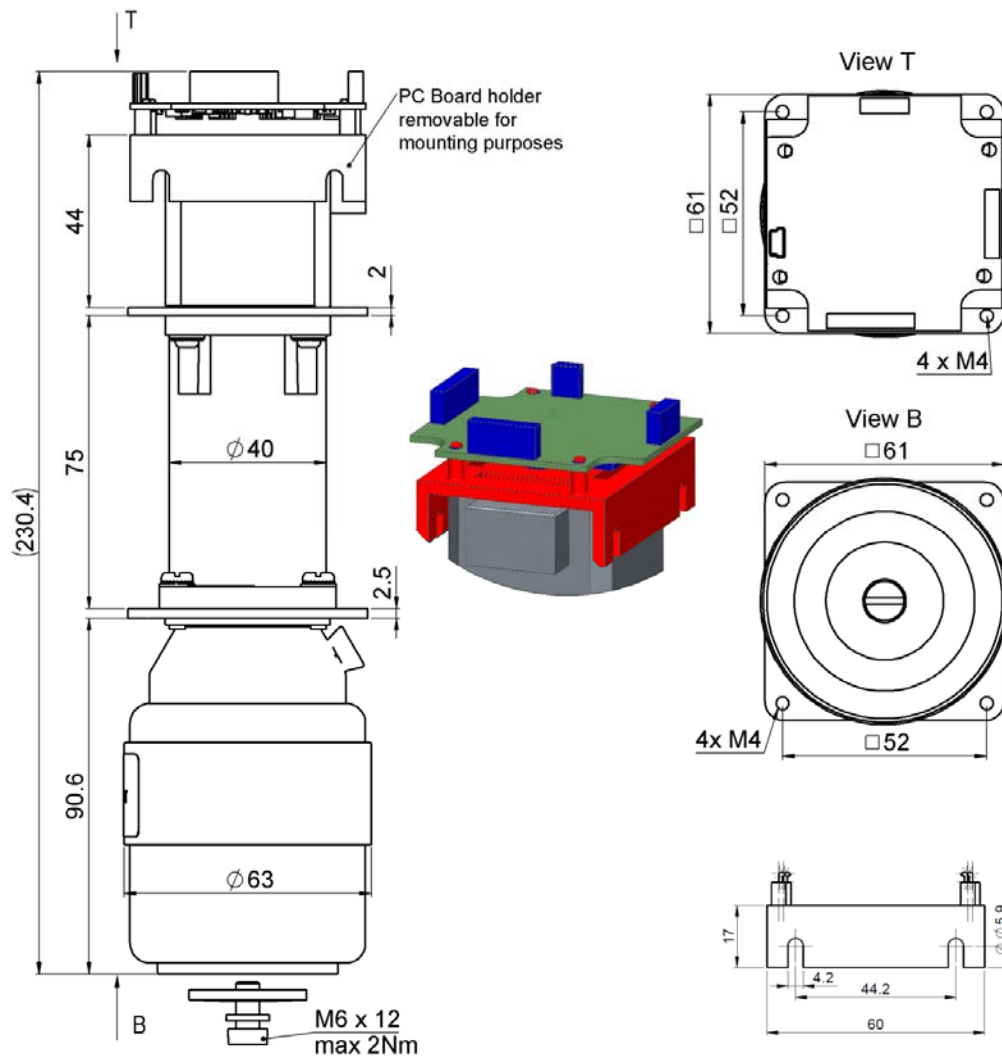

Fig. 4: Layout showing PCB and plastic PCB holder mounted correctly on stepper motor.

## 6 Revision history

Changes from document SB-63 V.1.1 to SB-63 Rev. 02:

Section	Description of change
General	Updated document to cover firmware version V.2.X in addition to V.1.X
2	Difference between Basic and Entry version

Changes from document SB-63 V.02 to SB-63 Rev. 03:

Section	Description of change
Chapter 5	Added UNIVERSAL variant